

SANTANDER SICAV

Société anonyme - société d'investissement à capital variable

Registered office: 43, Avenue John F. Kennedy

L- 1855 Luxembourg, Grand-Duchy of Luxembourg

R.C.S. Luxembourg number: B 45.337

(the "**Company**")

NOTICE TO SHAREHOLDERS OF THE SUB-FUND

SANTANDER GO GLOBAL EQUITY

(the "**Sub-Fund**")

Luxembourg, 22 May 2026

Dear Shareholder,

The board of directors of the Company (the "**Board**") would like to inform you about the following changes to be made to the Sub-Fund with effect as of 22 June 2026 (the "**Effective Date**").

The Board has decided to update the pre-contractual disclosures of the Sub-Fund in order to align them with the updated exclusion policy of its investment manager, Robeco Institutional Asset Management B.V., in line with its responsible investment framework.

These revisions reflect adjustments in the application of exclusion criteria and aim to ensure consistency between the Sub-Fund's documentation and the Investment Manager's policies.

As from the Effective Date, the relevant pre-contractual disclosures of the Sub-Fund will be updated accordingly.

As from the Effective Date, the investment objective, investment strategy and risk profile of the Sub-Fund will remain unchanged.

As from the Effective Date, the reference currency, fee structure, subscription, redemption and conversion conditions, as well as the investor profile of the Sub-Fund will remain unchanged.

Additionally, the Board informs that the costs associated with the above changes will not be borne by the Sub-Fund but by an entity of the Santander Group.

Please be advised that these changes will be reflected in an updated version of the Prospectus, which will be available free of charge at the registered office of the Company.

If you are not in agreement with the changes mentioned above, you may redeem your shares free of charge until 21 June 2026 in accordance with the usual redemption procedure foreseen in the Prospectus.

No suspension of subscriptions, redemptions or conversions is envisaged in connection with these changes.

Please do not hesitate to contact us or your financial adviser if you require any further clarification.

Yours faithfully,

For and on behalf of the Board

Appendix – New pre-contractual disclosures

Sustainable investment means an investment in an economic activity that contributes to an environmental or social objective, provided that the investment does not significantly harm any environmental or social objective and that the investee companies follow good governance practices.

The **EU Taxonomy** is a classification system laid down in Regulation (EU) 2020/852, establishing a list of **environmentally sustainable economic activities**. That Regulation does not include a list of socially sustainable economic activities. Sustainable investments with an environmental objective might be aligned with the Taxonomy or not.

Pre-contractual disclosure for the financial products referred to in Article 8, paragraphs 1, 2 and 2a, of Regulation (EU) 2019/2088 and Article 6, first paragraph, of Regulation (EU) 2020/852

Product name: SANTANDER GO GLOBAL EQUITY **Legal entity identifier:** 22210032M3

Environmental and/or social characteristics

Does this financial product have a sustainable investment objective?

<input checked="" type="checkbox"/> Yes	<input type="checkbox"/> No
<input type="checkbox"/> It will make a minimum of sustainable investments with an environmental objective: ___%	<input checked="" type="checkbox"/> It promotes Environmental/Social (E/S) characteristics and while it does not have as its objective a sustainable investment, it will have a minimum proportion of 50% of sustainable investments
<input type="checkbox"/> in economic activities that qualify as environmentally sustainable under the EU Taxonomy.	<input type="checkbox"/> with an environmental objective in economic activities that qualify as environmentally sustainable under the EU
<input type="checkbox"/> in economic activities that do not qualify as environmentally sustainable under the EU Taxonomy.	<input checked="" type="checkbox"/> with an environmental objective in economic activities that do not qualify as environmentally sustainable under the EU Taxonomy
<input type="checkbox"/> It will make a minimum of sustainable investments with a social objective: ___%	<input checked="" type="checkbox"/> with a social objective
<input type="checkbox"/> It promotes E/S characteristics, but any sustainable investments	<input type="checkbox"/> It promotes E/S characteristics, but any sustainable investments

Sustainability indicators

measure how the sustainable objectives of this financial product are attained.

What sustainability indicators are used to measure the attainment of each the environmental or social characteristics promoted by this financial product?

The Sub-Fund has the following sustainability indicators applied by the Investments Manager, Robeco Institutional Asset Management B.V. ("Robeco"):

1. The % of investments in securities that are on the Investment Manager's Exclusion list as result of the application of Robeco's Exclusion policy.
2. The number of companies that are in violation of the ILO standards, UNGPs, UNGC or OECD Guidelines for Multinational Enterprises.
3. The Sub-Fund's weighted carbon, footprint score compared to the general market index.
4. The Sub-Fund's weighted average ESG score compared to the general market index.
5. The % of holdings with an elevated sustainability risk profile.

What are the objectives of the sustainable investments that the financial product partially intends to make and how does the sustainable investment contribute to such objectives?

The sustainable investments aim to contribute to the UN Sustainable Development Goals ("SDGs"), that have both social and environmental objectives. These are 17 goals that are globally recognised and include environmental goals such as climate action, clean water, life on land and water and social goals such as zero hunger, gender equality, education, etc.

The Investment Manager uses its proprietary SDG Framework that is based on the UN SDGs, through which an issuer's contribution to such SDGs is determined through a 3-step process. This process starts with a sector baseline on which a company's products are analysed to examine contribution to the society and environment. Further, the operational processes involved in creating such products is checked along with any controversies/litigation claims and remediation actions taken which are perused before a final SDG score is determined. The final score ranges between high negative (-3) to high positive (+3) and only those issuers which achieve positive SDG scores (+1,+2 and, +3) are regarded as Sustainable Investments.

How do the sustainable investments that the financial product partially intends to make, not cause significant harm to any environmental or social sustainable investment objective?

The sustainable investments do no significant harm to any environmental or social sustainable investment objective by considering a principal adverse impact and aligning with the OECD Guidelines for Multinational Enterprises and the UN Guiding Principles on Business and Human Rights. In addition, sustainable investments score positively on the Investment Manager's SDG Framework, and therefore do not cause significant harm

How have the indicators for adverse impacts on sustainability factors been taken into account?

Mandatory principal adverse impact indicators are considered through the Investment Manager's SDG Framework, either directly or indirectly, when identifying sustainable investments for the Sub-Fund. In addition, voluntary environmental and social indicators are taken into account, depending on their relevance for measuring impacts on the SDGs and the availability of data. A detailed description of the incorporation of principal adverse impacts is available via Investment Manager's Principal Adverse Impact Statement published on the Investment Manager website. In this statement, Investment Manager sets out its approach to identifying and prioritizing principal adverse impact, and how principal adverse impacts are considered as part of Investment Manager's investment due diligence process and procedures relating to research and analysis, exclusions and restrictions and/or voting and engagement. This description also explains how principal adverse impact indicators are considered by the SDG Framework.

How are the sustainable investments aligned with the OECD Guidelines for Multinational Enterprises and the UN Guiding Principles on Business and Human Rights? Details:

Principal adverse impacts

are the most significant negative impacts of investment decisions on sustainability factors relating to environmental, social and employee matters, respect for human rights, anti- corruption and anti- bribery matters.

The sustainable investments are aligned with the OECD Guidelines for Multinational Enterprises and the UN Guiding Principles on Business and Human Rights via both the Investment Manager's Exclusion Policy and the Investment Manager's SDG Framework.

The Investment Manager's Exclusion Policy includes an explanation of how the Investment Manager acts in accordance with the International Labor Organization (ILO) standards, United Nations Guiding Principles (UNGPs), United Nations Global Compact (UNGC) Principles and the Organization for Economic Co-operation and Development (OECD) Guidelines for Multinational Enterprises and is guided by these international treaties to assess the behavior of companies. The Investment Manager continuously screens its investments for breaches of these principles.

In case of a breach, the company will be excluded or engaged with, and is not considered a sustainable investment.

The Investment Manager's SDG Framework screens for breaches on these principles in the final step of the framework. In this step, the Investment Manager checks whether the company concerned has been involved in any controversies. Involvement in any controversy will result in a negative SDG score for the company, meaning it is not a sustainable investment.

The EU Taxonomy sets out a “do not significant harm” principle by which Taxonomy-aligned investments should not significantly harm EU Taxonomy objectives and is accompanied by specific EU criteria.

The “do no significant harm” principle applies only to those investments underlying the financial product that take into account the EU criteria for environmentally sustainable economic activities. The investments underlying the remaining portion of this financial product do not take into account the EU criteria for environmentally sustainable economic activities.

Any other sustainable investments must also not significantly harm any environmental or social objectives.



What environmental and/or social characteristics are promoted by this financial product?

The Sub-Fund promotes environmental and/or social characteristics within the meaning of article 8 of the Regulation (EU) 2019/2088 of 27 November 2019 on sustainability-related disclosures in the financial sector ("SFDR").

The Sub-Fund has the following E/S characteristics:

1. The Sub-Fund promotes certain minimum environmental and social safeguards through applying exclusion criteria with regards to products and business practices that the Investment Manager believes are detrimental to society and incompatible with sustainable investment strategies, such as exposure to controversial behaviour, controversial weapons, and fossil fuels..
2. The Sub-Fund promotes adherence to and conducting business activities in accordance with the United Nations Universal Declaration of Human Rights, the International Labor Organization's (ILO) labor standards, the United Nations Guiding Principles for Business and Human Rights (UNGPs), the United Nations Global Compact (UNGC) and the OECD Guidelines for Multinational Enterprises.
3. The Sub-Fund promotes having a lower environmental footprint than the general market index.
4. The Sub-Fund promotes having a weighted average ESG score that is better than that of the general market index.
5. The Sub-Fund limits investing in companies with an elevated sustainability risk based on ESG risk scores whereas all such investments require separate approval of a dedicated committee that oversees that all investments are substantiated and eligible based on a fundamental review on the sustainability risk.

There is no reference benchmark designated for the purpose of attaining the environmental or social characteristics promoted by the Sub-Fund.



Does this financial product consider principal adverse impacts on sustainability factors?

Yes

No

The Sub-Fund considers principal adverse impacts on sustainability factors as referred to in Annex I of the SFDR Delegated Act.

Pre-investment, the following principal adverse impacts on sustainability factors are considered:

- Via the applied normative and activity-based exclusions, the following PAIs are considered:
 - Exposure to companies active in the fossil fuel sector (PAI 4, Table 1)
 - Violations of the UN Global Compact Principles and Organisation for Economic Cooperation and Development (OECD) Guidelines for Multinational Enterprises (PAI 10, Table 1)
 - Activities negatively affecting biodiversity-sensitive areas (PAI 7, Table 1). The consideration of this PAI is currently restricted to applying exclusions to palm oil producing companies and for any breaches to the UNGC, UNGP and OECD Guidelines for Multinational Enterprises in relation to biodiversity.
 - Exposure to controversial weapons (anti-personnel mines, cluster munitions, chemical weapons (PAI 14, Table 1)
- Via the ESG integration process, as part of the investment due diligence policies and procedures, the following PAIs are considered:
 - All indicators related to GHG emissions, as part of the required Climate Risk analysis (PAI 1-6, Table 1, PAI 4, Table 2)
 - Biodiversity, water and waste indicators (PAI 7-9, Table 1) when relevant for the sector
 - Board gender diversity (PAI 13, Table 1)
- Via the environmental footprint performance targets of the Sub-Fund, the following PAIs are considered:
 - Carbon footprint (PAI 2, Table 1)

Post-investment, the following principal adverse impacts on sustainability factors are taken into account:

- Via the Investment Manager's entity engagement program, the following PAIs are considered:
 - All indicators related to Climate and other environment-related indicators (PAI 1-9, Table 1)
 - Violations of the UN Global Compact Principles and Organisation for Economic Cooperation and Development (OECD) Guidelines for Multinational Enterprises (PAI 10, Table 1). On an ongoing basis, the investment universe is scanned for controversial behaviour in relation to the aforementioned principles and guidelines.
 - In addition, based on a yearly review of Robeco's performance on all mandatory and selected voluntary indicators, holdings of the Sub-Fund that cause adverse impact might be selected for engagement.

The Investment Manager considers the principal adverse impacts of investment decisions on sustainability factors in accordance with its own methodology and indicators. Further details can be found in the Investment Manager's Statement on the principal adverse impacts of investment decisions on sustainability factors, published on the Investment Manager's website and in the corresponding Statement of the Management Company which is available on www.santanderassetmanagement.lu.

Information on how principal adverse impacts on sustainability factors were considered for this Sub-Fund will be provided in the annual report.



What investment strategy does this financial product follow?

The investment strategy guides investment decisions based on factors such as investment

The Sub-Fund aims to select stocks with relatively low environmental footprints compared to stocks with high environmental footprints.

objectives and risk tolerance.

In addition to ESG integration, other sustainability criteria in relation to the Sub-Fund, such as exclusions, negative screening and active ownership (voting and engagement), are taken into account in the management of the Sub-Fund.

■ What are the binding elements of the investment strategy used to select the investments to attain each of the environmental or social characteristics promoted by this financial product?

The binding elements used in the selection of investments for the promotion of environmental, social and corporate governance characteristics are the criteria described in the investment strategy.

1. The Sub-Fund's portfolio complies with Robeco's Exclusion Policy Level 1 (<https://www.robeco.com/docm/docu-exclusion-policy.pdf>), that is based on exclusion criteria with regards to products and business practices that Robeco believes are detrimental to society. This means that the Sub-Fund has 0% exposure to excluded securities, taking into account a grace period. Information with regards to the impact of the exclusions on the Strategy's universe can be found at <https://www.robeco.com/docm/docu-exclusion-policy.pdf>.

2. The Mandate avoids investment in companies that are in breach of the ILO standards, UNGPs, UNGC or OECD Guidelines for Multinational Enterprises. Companies that breach the international norms will be excluded from the investment universe.

3. The Sub-Fund's weighted carbon, footprint score is 20% better than that of the General market index.

4. The Sub-Fund's weighted average ESG score is better than that of the General market index.

5. Investments with an elevated sustainability risk are defined by Robeco as companies with an ESG Risk Rating of 40 and higher (the ESG Risk Rating is explained in the Sustainability Risk Policy which can be accessed via <https://www.robeco.com/files/docm/docu-robeco-sustainability-risk-policy.pdf>). The Sub-Fund is limited to a maximum exposure of 2% to investments with an elevated sustainability risk, based on the market weight in the portfolio taking into account regional differences and benchmark. Each investment with an ESG Risk rating of higher than 40 requires separate approval by a dedicated committee of SI specialists, compliance and risk management that oversees the bottom-up sustainability analysis. The minimum percentage of sustainable investment of this Sub-Fund is 50%.

■ What is the committed minimum rate to reduce the scope of the investments considered prior to the application of that investment strategy?

The Sub-Fund does not commit to a minimum rate to reduce the scope of investments prior to the application of the investment strategy.

Good governance practices include sound management structures, employee relations, remuneration of staff and tax compliance.

● What is the policy to assess good governance practices of the investee companies?

The Investment Manager has a Good Governance policy to assess governance practices of companies. The policy describes how the Investment Manager determines if and when a company does not follow good governance practices and is therefore excluded from the initial investment universe for Article 8 and 9 products. The Investment Manager's Good Governance policy applies to the Sub-Fund and tests on a set of governance criteria that reflect widely recognized industry-established norms and include topics as employee relations, management structure, tax compliance and remuneration.

The Good Governance test consists of criteria on such topics that are examined for investee companies and further explained in the Good Governance Policy <https://www.robeco.com/files/docm/docu-robeco-good-governance-policy.pdf>. Additionally, the companies that do not pass the good governance test are reflected in the exclusion list that can be accessed here: <https://www.robeco.com/files/docm/docu-exclusion-list.pdf>.



are sustainable investments with an environmental objective that do that **do not take into account the criteria** for environmentally sustainable economic activities under the EU Taxonomy.

● **What is the minimum share of investments in transitional and enabling activities?**

The Sub-Fund has a minimum share of 0% in transitional activities and of 0% in enabling activities.



● **What is the minimum share of sustainable investments with an environmental objective that are not aligned with the EU taxonomy?**

The Sub-Fund intends to make sustainable investments, measured as positive scores via Investment Manager's SDG Framework. Among those could be investments with social objectives that do not qualify as Taxonomy-aligned. The environmental objectives of the Sub-Fund are attained by investing in companies that score positively on SDG 12 (Responsible consumption and production), SDG 13 (Climate action), SDG 14 (Life below water), and SDG 15 (Life on land) in Robeco's SDG Framework. While the sum of environmentally sustainable investments and sustainable investments with a social objective always adds up to the Sub-Fund's minimum proportion of 50% sustainable investments, we do not commit to a minimum share of sustainable investments with an environmental objective that are not aligned with the EU Taxonomy because the Sub-Fund's investment strategy does not have a specific environmentally sustainable investment objective. Therefore, the minimum share of sustainable investments with an environmental objective is 0%.



● **What is the minimum share of sustainable investments with a social objective?**

The Sub-Fund does not have a minimum commitment on sustainable investments with a social objective. The Sub-Fund makes investments with both an environmental and a social objective.

The Sub-Fund intends to make sustainable investments, measured as positive scores via Investment Manager's SDG Framework. Among those could be investments with social objectives. The social objectives of the Sub-Fund are attained by investing in companies that score positively on SDG 1 (No poverty), SDG 2 (Zero hunger), SDG 3 (Good health and well-being), SDG 4 (Quality education), SDG 5 (Gender equality), SDG 6 (Clean water and sanitation), SDG 7 (Affordable and clean energy), SDG 8 (Decent work and economic growth), SDG 9 (Industry, innovation and infrastructure), SDG 10 (Reduced inequalities), SDG 11 (Sustainable cities and communities), SDG 16 (Peace, justice and strong institutions) and SDG 17 (Partnerships for the goals), in Robeco's SDG Framework. While the sum of socially sustainable investments and sustainable investments with an environmental objective always adds up to the Sub-Fund's minimum proportion of 50% sustainable investments, we do not commit to a minimum share of socially sustainable investments because the Sub-Fund's investment strategy does not have a specific socially sustainable investment objective. While the sum of socially sustainable investments and sustainable investments with an environmental objective always adds up to the Sub-Fund's minimum proportion of 50% sustainable investments, we do not commit to a minimum share of socially sustainable investments because the Sub-Fund's investment strategy does not have a specific socially sustainable investment objective. Therefore, the minimum share of socially sustainable investments is 0%.



● **What investments are included under “#2 Other”, what is their purpose and are there any minimum environmental or social safeguards?**

The type of instruments included under "#2 Other" and their purpose are amongst others, the use of cash, cash equivalents and derivatives. as well as investment funds and eligible asset classes (other than bonds and equities) that do not specifically promote E/S characteristics. As indicated above, the Sub-

Fund does not make use of derivatives to attain the environmental or social characteristics promoted. The Sub-Fund may make use of derivatives, which thus always fall under the category "#2 Other", for hedging, liquidity management and efficient portfolio management as well as investment purposes. Exchange traded and over-the-counter derivatives are permitted, including but not limited to futures, swaps, options and currency forwards. In case the Sub-Fund uses derivatives, the underlying shall comply with the investment policy. Where relevant, minimum environmental or social safeguards are taken into account, by, for example, applying the Investment Manager's Exclusion Policy for any single security derivative.



What is the asset allocation planned for this financial product?

Asset allocation describes the share of investments in specific assets.

Taxonomy-aligned activities are expressed as a share of:

- **turnover** reflecting the share of revenue from green activities of investee companies
- **capital expenditure** (CapEx) showing the green investments made by investee companies, e.g. for a transition to a green economy.
- **operational expenditure** (OpEx) reflecting green operational activities of investee companies.

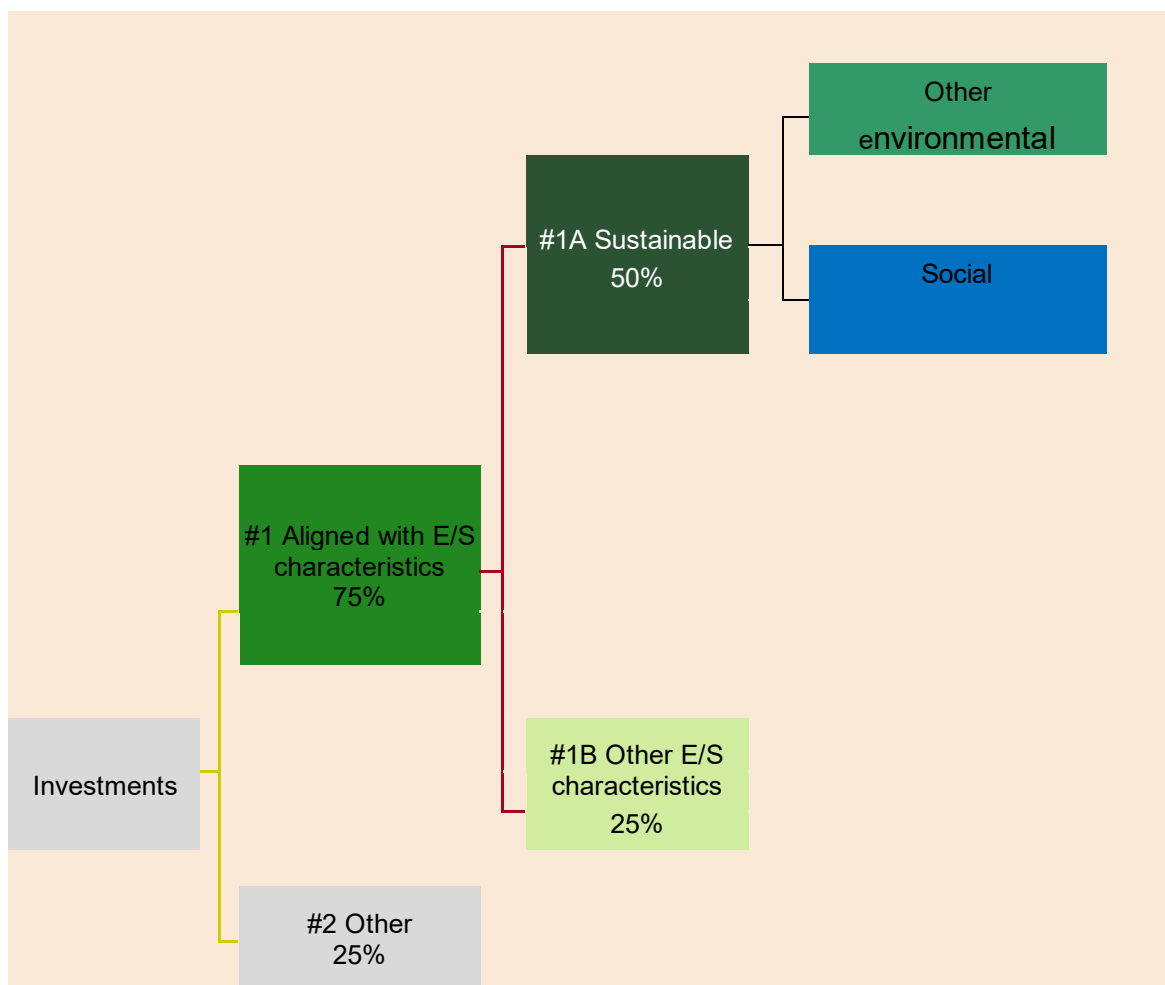

At least 90% of the investments are aligned with the E/S characteristics of the Sub-Fund. The Sub-Fund plans to make a minimum of 50% sustainable investments, measured by positive scores via Robeco's SDG Framework. The investments in the category Other are mostly in cash and cash equivalents. The planned asset allocation is monitored continuously, and evaluated on a yearly basis.

Please note that:

#1 Aligned with E/S characteristics includes the investments of the financial product used to attain the environmental or social characteristics promoted by the financial product.

#2 Other includes the remaining investments of the financial product which are neither aligned with the environmental or social characteristics, nor are qualified as sustainable investments.

The category #1 Aligned with E/S characteristics covers:

- The sub-category #1A Sustainable covers sustainable investments with environmental or social objectives.

- The sub-category #1B Other E/S characteristics covers investments aligned with the environmental or social characteristics that do not qualify as sustainable investments.

Please note that, for the sake of clarity, the percentages related to Sustainable Investments (#1A) and other E/S characteristics (#1B) are calculated based on the total investments and not only on those aligned with E/S characteristics.

● **How does the use of derivatives attain the environmental or social characteristics promoted by the financial product?**

The Sub-Fund does not make use of derivatives to attain the environmental or social characteristics promoted by the Sub-Fund. The Sub-Fund may make use of derivatives for both hedging, liquidity and efficient portfolio management as well as investment purposes. Exchange traded and over-the-counter derivatives are permitted, including but not limited to futures, swaps, options and currency forwards. Whilst the Sub-Fund may use derivatives both for investment purposes as well as for hedging and efficient portfolio management, it does not utilize derivatives for such purposes outside the intended share of investments allocated to the 'Other' category.



To what minimum extent are sustainable investments with an environmental objective aligned with the EU Taxonomy¹⁵?

The sub-fund does not intend to make taxonomy-aligned sustainable investments and alignment has therefore been assessed to be 0%. It cannot be excluded that among the Sub-fund's holdings certain investments are Taxonomy aligned. The Sub-Fund will report on Taxonomy-aligned investment in the periodic disclosures. In the future, once data-availability in relation to the EU Taxonomy will improve, the Investment Manager might consider setting a target based on turnover or CAPEX. The Investment Manager currently relies on third-party data, including data in relation to companies that do not disclose on the EU Taxonomy alignment of their activities. EU Taxonomy-alignment data is not yet subject to a review by third parties. The Sub-Fund only makes investments in equity and therefore it does not have sovereign exposures. The expected level of alignment with and without sovereign bonds is the same.

● **Does the financial product invest in fossil gas and/or nuclear energy related activities that comply with the EU Taxonomy¹?**

- Yes
 - In fossil gas
 - In nuclear energy
- No

The two graphs below show in green the minimum percentage of investments that are aligned with the EU Taxonomy. As there is no appropriate methodology to determine the taxonomy-alignment of sovereign bonds*, the first graph shows the Taxonomy alignment in relation to all the investments of the financial product including sovereign bonds, while the second graph shows the Taxonomy alignment only in relation to the investments of the financial product other than sovereign bonds.



To comply with the EU Taxonomy, the criteria for **fossil gas** include limitations on emissions and switching to renewable power or low-carbon fuels by the end of 2035. For **nuclear energy**, the criteria include comprehensive safety and waste management rules.

Enabling activities directly enable other activities to make a substantial contribution to an environmental objective.

Transitional activities are activities for which low-carbon alternatives are not yet available and among others have greenhouse gas emission levels corresponding to the best performance.

¹³ Fossil gas and/or nuclear related activities will only comply with the EU Taxonomy where they contribute to limiting climate change ("climate change mitigation") and do not significantly harm any EU Taxonomy objectives -see explanatory note in the left-hand margin. The full criteria for fossil gas and nuclear energy economic activities that comply with the EU Taxonomy are laid down in Commission Delegated Regulation (EU) 2022/1214.

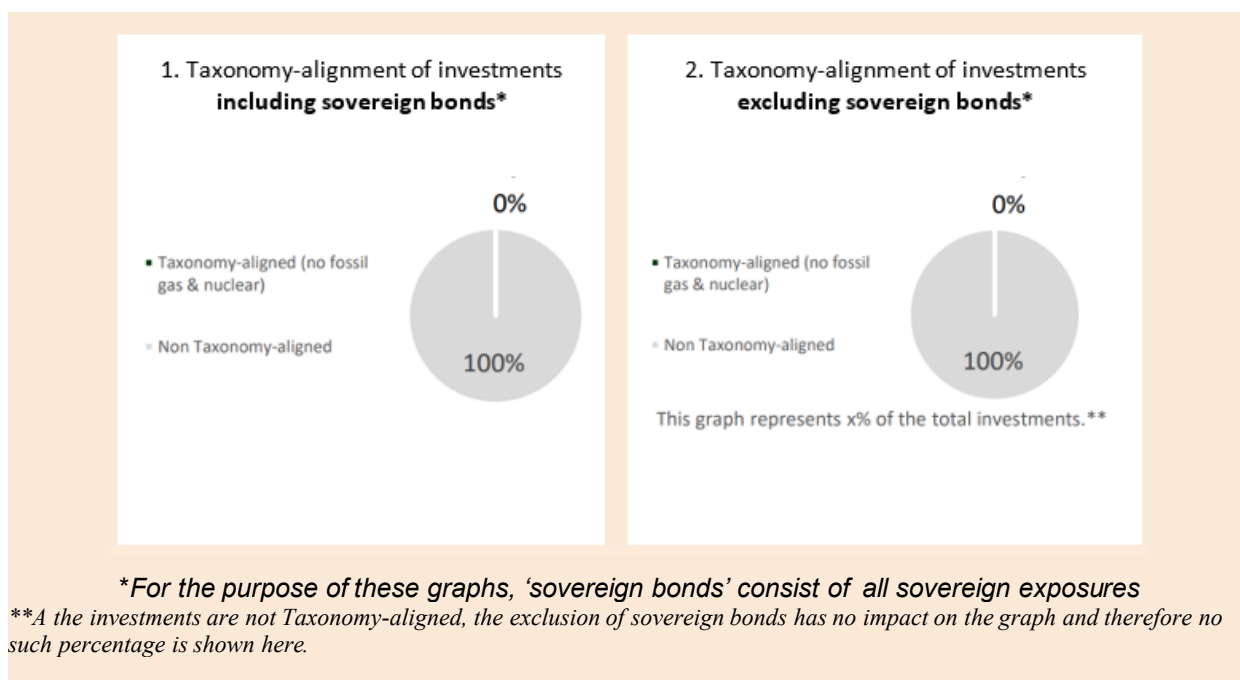

Reference benchmarks are indexes to measure whether the financial product attains the sustainable investment objective.

Is a specific index designated as a reference benchmark to determine whether this financial product is aligned with the environmental and/or social characteristics that it promotes?

N/A



Where can I find more product specific information online?

Further information specific to this Sub-Fund can be found on the website <https://www.santanderassetmanagement.lu/document-library/policies>